

Bottle Packaging Line Components

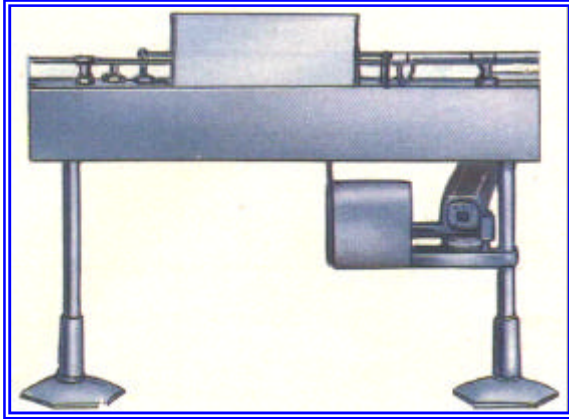

INSPECTION UNIT - TILTING TYPE

- Designed specially for round bottles.
- Round bottles automatically tilt and roll in front of fluorescent light. Flat bottles pass jerkily in front of the fluorescent light.
- Provided with a 5' length end to end stainless steel slat conveyor.
- Provided with a 2' inspection box with fluorescent light fittings.
- Suitable for only one operator.

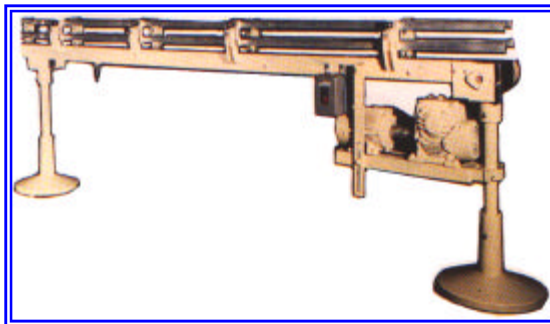

MC STAINLESS STEEL SLAT CONVEYOR

- Slats made of stainless steel 304, M.S.
- Available in-3.25' 4' and 6" width slats. Other sizes on request.
- Mounted on a rigid M.S. frame with aluminum guide rails.
- Can also be mounted on SS 304 frame except legs and 'u' bracket at extra cost (optional)
- Provided with quick adjustment guide accessories made of polypic.
- Provided with suitable reduction

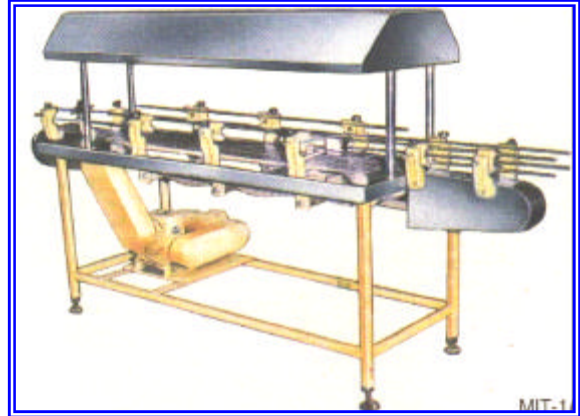

THREE WAYS INSPECTION UNIT

- Bottles to be inspected are lifted manually, checked against a fluorescent light source located in the hood and then placed on to the center conveyor to proceed for further operation.
- Round bottles are divided into two rows for inspectors to sit on either side for inspection. Suitable for 2 or 4 operators depending upon the length of the unit.
- Flat bottles are received on one conveyor, checked and placed on the adjacent track to proceed for further operation.
- Conveyor of 3/4' width SS slats
- Hood made of S.S. 304 sheet.
- Inspection panel of Sunmaica / Formica.

gearbox and motor depending upon the length of conveyor.

- Can be provided with variable speed drive at extra cost (optional).
- Suitable for conveying regular shaped container likes round, flat, square etc. over any lengths.
- Gravity roller & power conveyors available.

System Component Exported by:

ENCON Consulting Engineers

M-28, 7th Floor, Marigold,

Krishnakeval Township,

Kondhwa Khurd, Pune 411048-INDIA.

Tel/Fax: +91 20 26831210 Cell Phone: +91 94 22 00 2758

Email: encon@vsnl.com / enconindia@hotmail.com

