

Direct Expansion Bulk Milk Cooling Tanks



Compact, Easy to Clean, High Performance
and
Free Standing.
Type EC/DE
Direct Expansion
Capacity 300 to 3,500 Liters

System Component Exported by:

ENCON Consulting Engineers

M-28, 7th Floor, Marigold,

Krishnakeval Township,

Kondhwa Khurd,

Pune 411048-INDIA.

Tel/Fax: +91 20 26831210

Cell Phone: +91 94 22 00 2758



Email: encon@vsnl.com / enconindia@hotmail.com

Type EC/DE Direct Expansion Capacity 300 to 3,500 Liters

Special Features:

- Compact, Low Standing Easy to Clean
- Stand alone Space Saving Design.
- Air cushioned Spring assisted one piece cover
- Large Cooling Area & CAD Designed shape guarantee effective cooling.
- Std. 50 NB plug or butterfly valve as optional.
- Sandwich Construction polyurethane foam insulation for min. heat loss.
- Control Panel body mounted or separate.

- Design. Direct expansion enables optimal heat exchange
- Entire construction in Stainless Steel material with Dairy Hygiene Standard.
- Refrigeration equipment either body mounted or separate as required.
- Adjustable support leg for slope adjustment.
- Low powered, noiseless agitator for efficient mixing & preventing milk freezing.

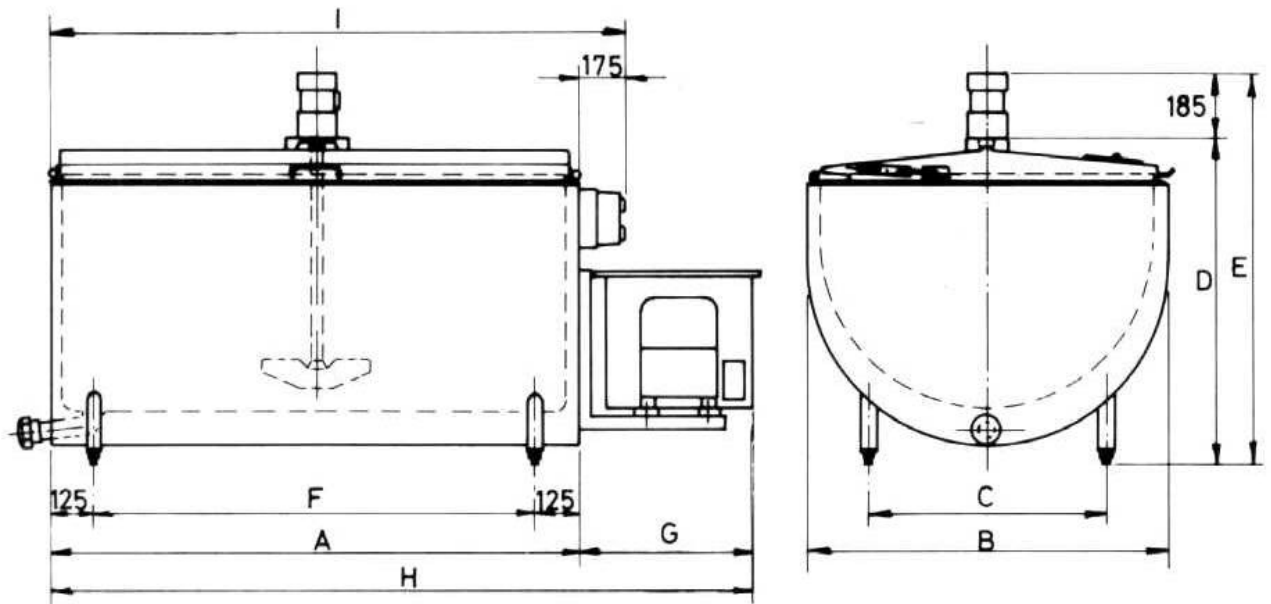

Model EC/DE	A	B	C	D	E	F	G	H	I	Capa. Liters	Weight Kg.
600	1550	900	600	1000	1200	1300	550	2100	1700	650	225
1200	2300	1100	700	1000	1200	2050	550	2900	2500	1270	300

System Component Exported by:

ENCON Consulting Engineers

M-28, 7th Floor, Marigold,
Krishnakeval Township,

Kondhwa Khurd,
Pune 411048-INDIA.

Tel/Fax: +91 20 26831210

Cell Phone: +91 94 22 00 2758



Email: encon@vsnl.com / enconindia@hotmail.com