

Milk Can Conveyor For Dairy Industries.

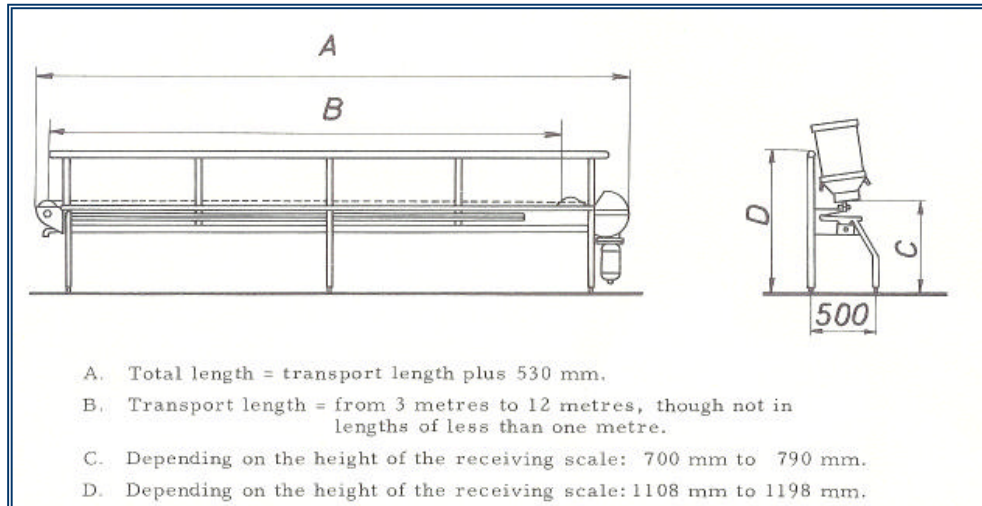

Specifications / Features:

- 1) Total Stainless Steel SS-304 Construction.
- 2) Design to Dairy Hygiene Standard.
- 3) Adjustable to 20, 40 or 50 Liters Milk Cans.
- 4) Optional Drip Saver for Return line Conveyor.
- 5) Double Flat Chain option for Milk Reception area for filled can transport.
- 6) Optional Auto Conveyor Stop arrangement.
- 7) Quick installation with adjustable ball feet & separate pin support for Chain Conveyor.
- 8) Return chain travel through pipe which can be rinsed cleaned with water.

Engineered & Exported by:

ENCON Consulting Engineers

M-28, 7th Floor, Marigold,

Krishnakeval Township,

Kondhwa Khurd,

Pune 411048-INDIA.

Tel/Fax: +91 20 26831210

Cell Phone: +91 94 22 00 2758



Email: encon@vsnl.com / enconindia@hotmail.com