

Insulated Portable Milk Tanks



Pallet Mounted Type

Insulated Portable Milk tanks are essentially required in tropical countries for Milk collections from remotely located Farmers or Chilling centers.

Available in wide variety sizes shapes & attached accessories.

Advantages:

- i) Compact,
- ii) Sturdy,
- iii) Hygiene Std.
- iv) C.I.P compatible.
- v) Stackable.

Available Sizes:

The tanks are custom-built to meet specific application requirements. Generally most suitable in Capacity Size range from 500 to 2000 Liters.

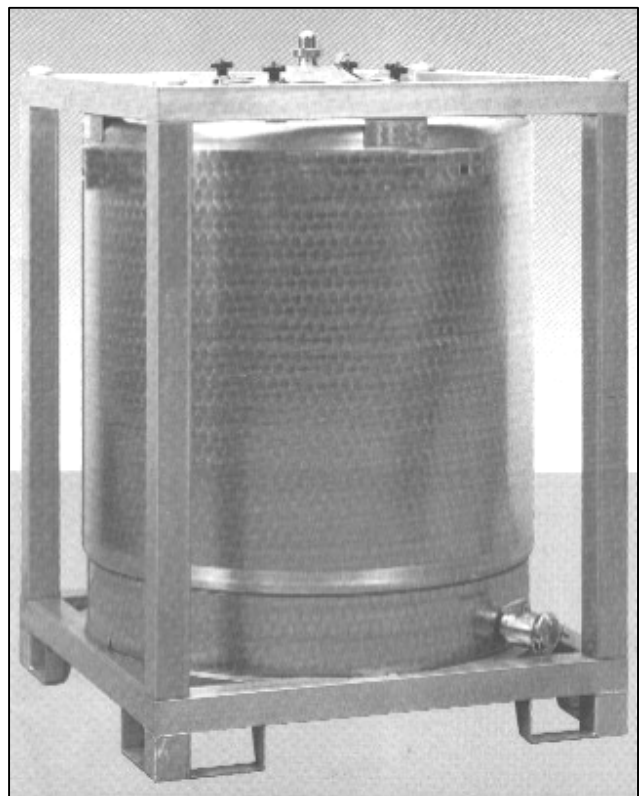
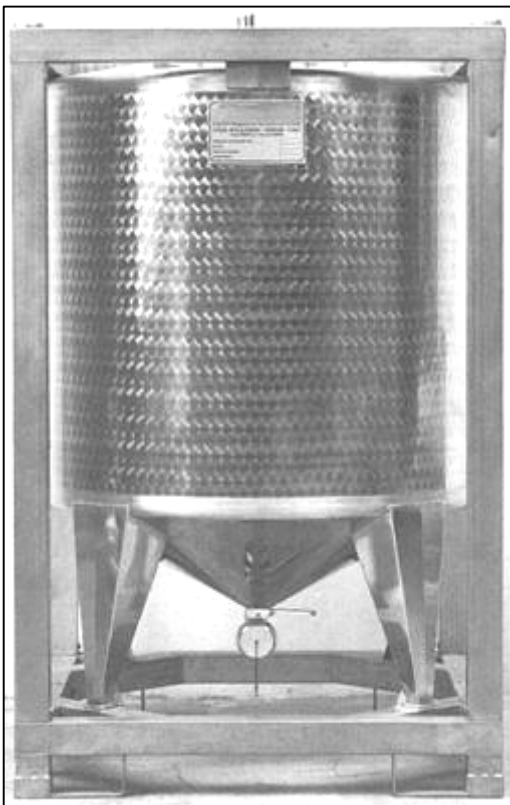

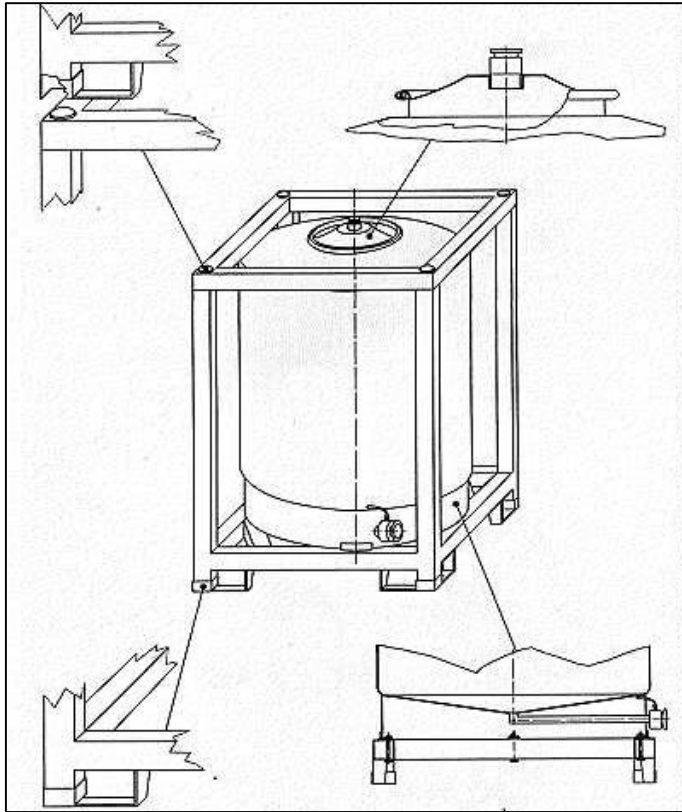

Typical Arrangement.

Inner Tank: SS-0304 / 316
Insulation: Styrofoam
 Puff (Optional)
Cladding: Powder Coated
 Steel or
 SS-304 (Optional)
Frame: Powder Coated
 Steel or
 SS-304 (Optional)
Connection: SMS Dairy Fitting
 IDF (Optional)
ManHole: Top Cover
 Front (Optional)

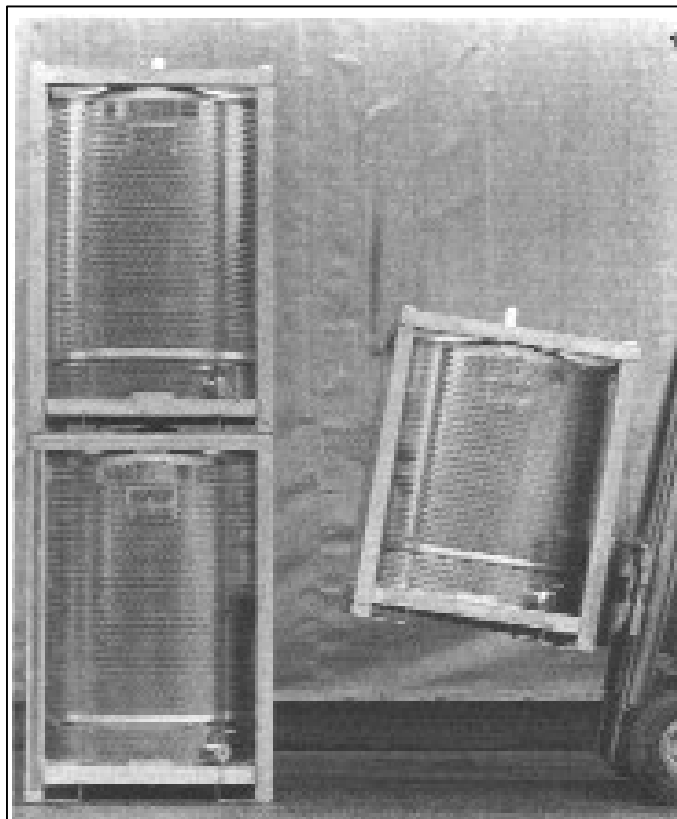

Easy to Stack with Fork Lift

Engineered & Exported by:

ENCON Consulting Engineers

M-28, 7th Floor, Marigold,
 Krishnakeval Township,
 Kondhwa Khurd,
 Pune 411048-INDIA.

Tel/Fax: +91 20 26831210

Cell Phone: +91 94 22 00 2758

Email: encon@vsnl.com / enconindia@hotmail.com

